

CTX40/70

Electric Tow Tractor

48V, AC Drive

Pneumatic or Super Elastic Tyres

4.000 kg 7.000 kg

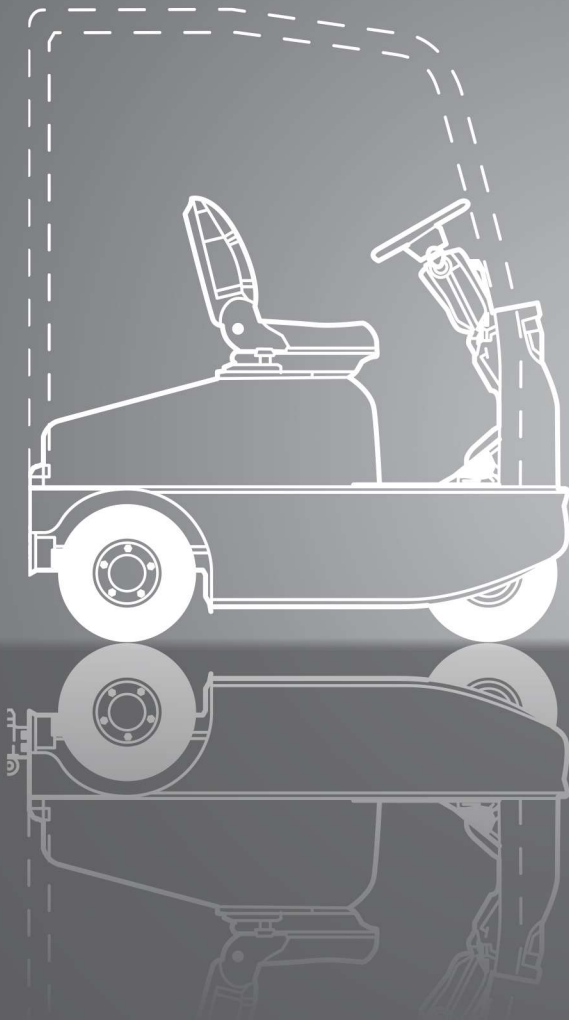

DIMENSIONS

CTX40/70

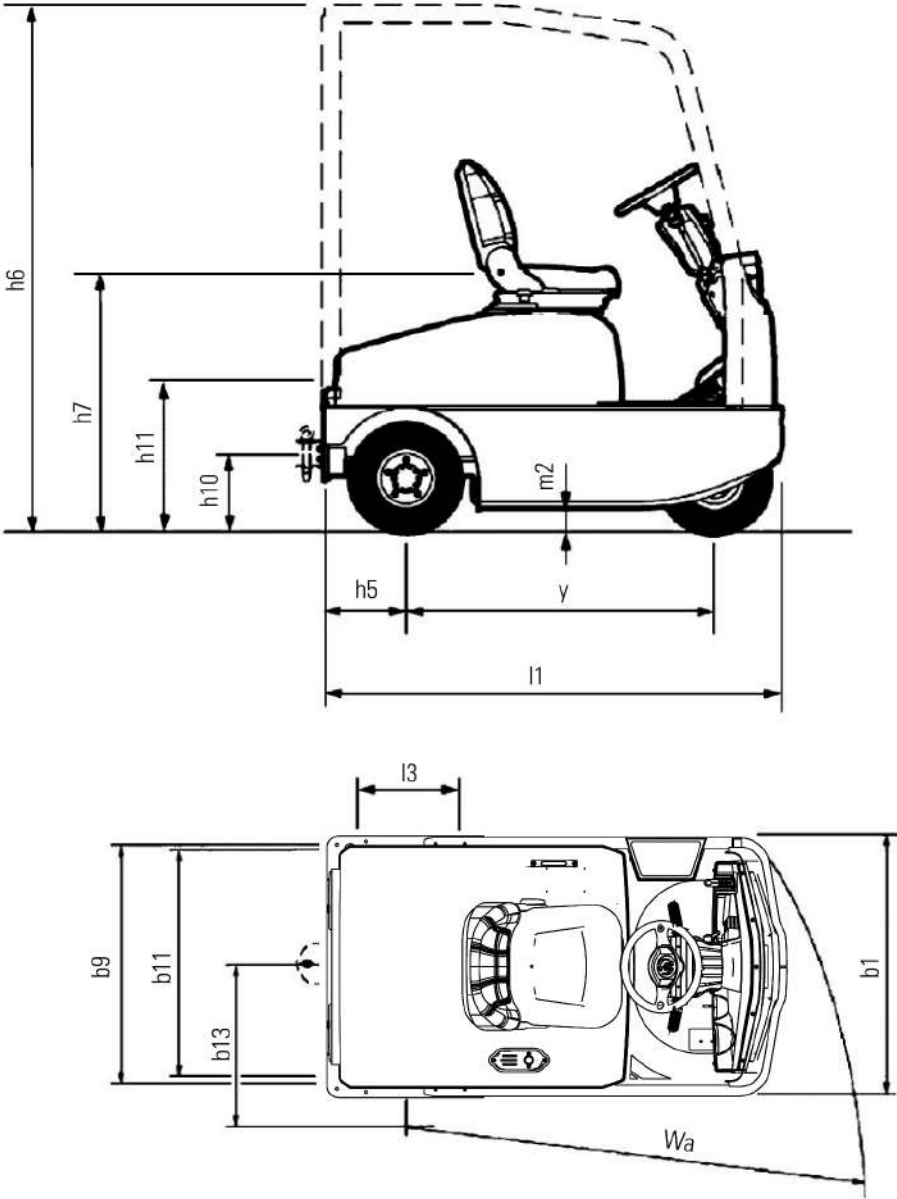

Gradeability

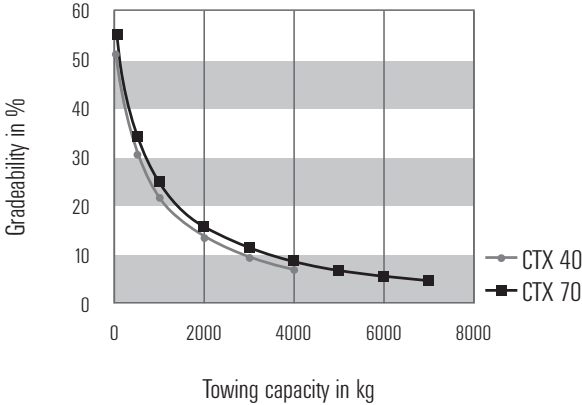

The gradeability diagram shows the combination of towing capacity and gradeability of the tow tractor. Contact your CLARK dealer to find out more about your individual application. Note: Applicable for friction coefficient $\mu=0.6$ with 1.6 km/h

SPECIFICATIONS

Product Specifications acc. to VDI 2198

	1.1 Manufacturer (abbreviation)	CLARK	CLARK
Specifications	1.2 Manufacturer's type designation	CTX40	CTX70
	1.3 Drive unit	Electric	Electric
	1.4 Operator type	Rider seated	Rider seated
	1.5 Load capacity/rated load Q (t)	4	7
	1.7 Rated drawbar pull N	785	1393
	1.9 Wheelbase y (mm)	1160	1160
Weight	2.1 Service weight kg	910	1050
	2.3 Axle loading, unladen front/rear kg	390/520	430/620
Tyres, Chassis	3.1 Tyre type, P=pneumatic, SE=super elastic, C=cushion *1	P	P
	3.2 Tyre size front	4.00-8/6PR	4.00-8/6PR
	3.3 Tyre size rear	4.00-8/6PR	4.00-8/6PR
	3.5 Wheels number front/rear (x=drive wheels)	1/2x	1/2x
	3.7 Tread rear b11 (mm)	870	870
Dimensions	4.7 Height overhead guard (weatherproof cabin (optional)) h6 (mm)	2035	2035
	4.8 Seat height h7 (mm)	920	920
	4.12 Coupling height h10 (mm)	295	295
	4.13 Loading height, unladen h11 (mm)	605	605
	4.16 Length of loading surface l3 (mm)	420	420
	4.17 Overhang l5 (mm)	310	310
	4.18 Width of loading surface b9 (mm)	767	767
	4.19 Overall length (with hinge/without hinge) l1 (mm)	1830/1730	1830/1730
	4.21 Overall width b1, b2 (mm)	995	995
	4.32 Ground clearance, center of wheelbase m2 (mm)	90	90
Performance	4.35 Turning radius Wa (mm)	1700	1700
	4.36 Minimum pivoting point distance b13 (mm)	551	551
	5.1 Travel speed laden/unladen km/h	9/13	7/17
	5.6 Max. drawbar pull laden/unladen *2 N	-/5394	-/5982
	5.8 Max. gradeability laden/unladen *2 %	-/51.1	-/55.6
Drive line	5.10 Service brake	Drum brake	Drum brake
	6.1 Drive motor rating, S2 60min kW	3.0	6.0
	6.3 Battery acc. to DIN 43531/35/36 A,B,C, no	DIN 43531 A	DIN 43531 A
	6.4 Battery voltage/nominal capacity K5 V/Ah	48/270	48/375
	6.5 Battery weight kg	476	560
Miscellaneous	8.1 Drive motor control	Inverter/AC	Inverter/AC
	8.4 Sound level, driver's ear *3 dB (A)	68.4	68.5
	8.5 Towing coupling, class/type DIN	Bolt	Bolt

*1) Optional with super elastic tyres *2) At friction coefficient $\mu=0.6$ with 1.6 km/h *3) acc. to DIN EN 12053

PRODUCT DESCRIPTION



The CLARK CTX40/70 electric powered tow tractor with 4 and 7 ton towing capacity is the dependable ideal choice for many applications. Whenever efficient transport of multiple trailers or wheeled loads is required, the rugged construction ensures durability and consistent reliability for many applications. The operator compartment provides a safe, comfortable working environment.

Operator's compartment

Access to the ergonomically designed operator's compartment is via a low easy positioned entry. A full width rubber floor covering in the footwell area is uncluttered and prevents slippage. The impressive leg room, the adjustable steering column with two spoke steering wheel together with an easy-to-adjust, suspension CLARK seat, allow perfect positioning for any driver. All controls are placed in easy-grip position. Large accessible storage compartments, as well as quick access to an ideally positioned automotive style hand brake and emergency stop button complete this impressive operator's compartment. A generous 150 kg capacity storage area (767 mm width x 420 mm length) located behind the driver's seat allows easy storage of ancillary items. The battery charge indicator is located within easy view of the operator giving instant battery condition information at all times. The optional inching function allows smooth approach to the trailer for easy hook up. Slow creep speed is available via the optional creep speed function allowing full customization of the tractor to every application.

Motor, drive and control

A powerful 3.0 kW AC motor (CTX40) or 6.0kW (CTX70) driving the rear wheels and 48 volt three-phase technology ensure excellent acceleration, smooth control and high performance. The maintenance free AC motors ensure running costs are kept to a minimum. The temperatures of the motors and controller are constantly monitored with the power being automatically adjusted to prevent design limits being exceeded. The ZAPI AC controls are easily accessible and equipped with modern MOSFET and CAN-bus technology. Travel speeds, even under load are a major feature of the CTX range of tow tractors from CLARK.

Brake system

Three independent brake systems (electrical, foot and parking brake) ensure increased efficiency through improved utilization of the battery capacity and high levels of safety. The foot and parking brake provides constant brake performance in all conditions. The regenerative electrical brakes returns energy to the battery during each braking action. This process saves energy costs, reduces brake wear and extends the driving time per battery charge. If the driving direction is changed by operation of the direction lever, the electronics ensures gentle braking and progressive acceleration in the new direction of travel. The drum brakes are protected against aggressive particles. The standard ramp start feature enables controlled operation of the truck on gradients and precise handling on loading platforms. The parking brake is connected via a Bowden cable directly to the drum brake.

Steering system

The CTX series from CLARK is designed "Built to Last®" and is characterized by an especially strong frame construction, making it suitable for the toughest applications. The centre of gravity of the chassis is extremely low giving excellent stability when cornering. An extremely small turning radius of 1700 mm is possible due to the large steering angle. Precise steering control is constant even with the steering on full lock.

Additional standard equipment

Front working lights, combination rear lights incorporating brake and reversing lights, paint-work in the bright safety colour "CLARK Green", rims in white, hydraulic drum brake, storage cargo box with 150 kg of carrying capacity, tiltable steering wheel with spinner knob.

Options

Solid tyres, cabins, inching switch, creep switch, back up alarm, reverse mirror, LED lighting, various trailer hitches, non-marking tyres.

Certification

The CTX40/70 series is CE certified and corresponds to all European safety standards.

Contact your CLARK dealer to find the optimum equipment for you.

